



bioenergy2020+

# BioResHybrids in AUSTRIA

Ernst Höftberger  
BIOENERGY 2020+

Brussels, June 15th 2016



# Content

- Status Quo - Austria
- Potential
- Existing applications and ongoing developments
- Summary / Outlook

# Status Quo - Austria

- Share Renewables: ~31%
- Continuously increasing

Struktur des Bruttoinlandsverbrauches im Jahr 2013

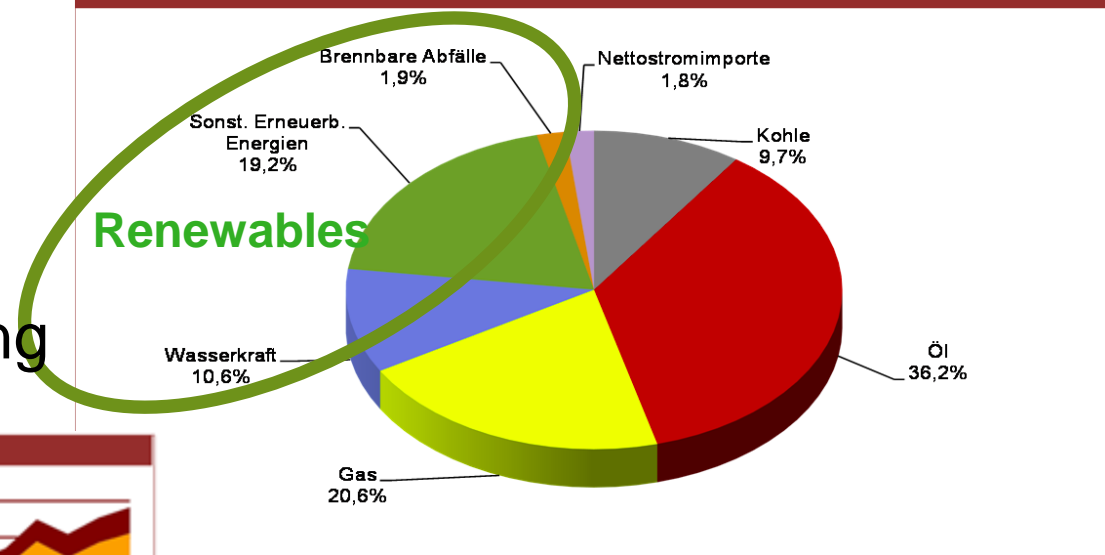

Energetischer Endverbrauch erneuerbarer Energien 2013

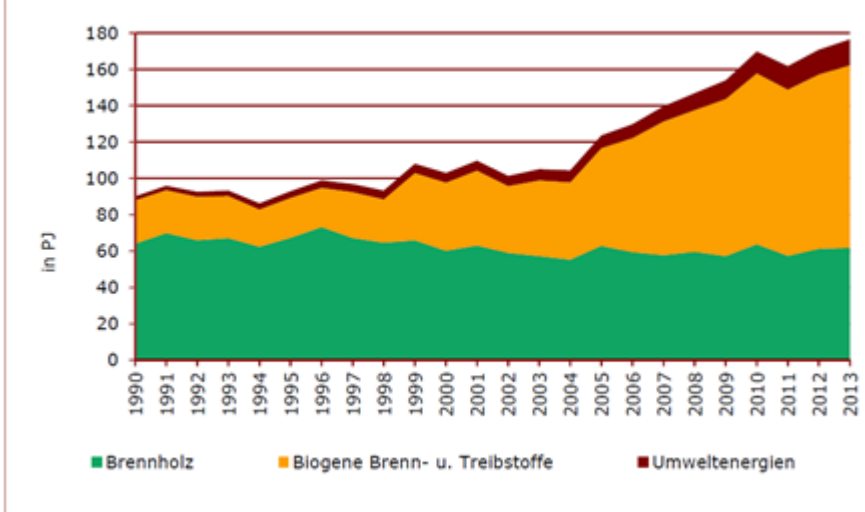

## Energy Consumption in Austria 2013

<http://www.bmwf.gv.at/EnergieUndBergbau/Energiebericht/Documents/Energiestatus%20%C3%96sterreich%202015.pdf>



# Incentives

## ■ Private households:

- PV: 275-375 €/kW<sub>peak</sub>
- Heating systems based on woody biomass (500 – 2000€/unit)
- Solar thermal heating systems and/or warm water production (750-1.500€)

## ■ Companies:

- Solar thermal – process heat, heating grids,...)
- PV: 275-375 €/kW<sub>peak</sub>

**→ But up to now no incentives for hybrid systems!**



## Potential - The Austrian technology and innovation roadmap “bioheating and cooling”

- Increase of biomass in the energy mix from 20% (2010) to almost 50 % of total energy consumption for space heating and hot water production in 2035.
- This is approximately 130 PJ.
- Major part of future installations are expected to be equipped with hybrid technologies (reference: biomass/solar hybrid system) - a potential of roughly 20-30 PJ can be estimated.
- Additional contributions are expected from other hybrid solutions for medium and large scale applications

[http://www.nachhaltigwirtschaften.at/nw\\_pdf/1254\\_fti\\_roadmap\\_bioheating\\_and\\_cooling.pdf](http://www.nachhaltigwirtschaften.at/nw_pdf/1254_fti_roadmap_bioheating_and_cooling.pdf)  
[http://www.nachhaltigwirtschaften.at/e2050/e2050\\_pdf/201426\\_marktentwicklung\\_2013.pdf](http://www.nachhaltigwirtschaften.at/e2050/e2050_pdf/201426_marktentwicklung_2013.pdf)

# Biomass Boiler – Solar Thermal Ökofen - Pellesol

- Optimized buffer tank for pellet/solar combination
- Includes up to two circulation pumps
- Warm water module
- Heating system connectivity



[www.pelletsheizung.at](http://www.pelletsheizung.at)

# Biomass Boiler – Solar Thermal Solarfocus - Octoplus

- Combustion chamber integrated into buffer tank
- Reduced thermal losses of combustion chamber

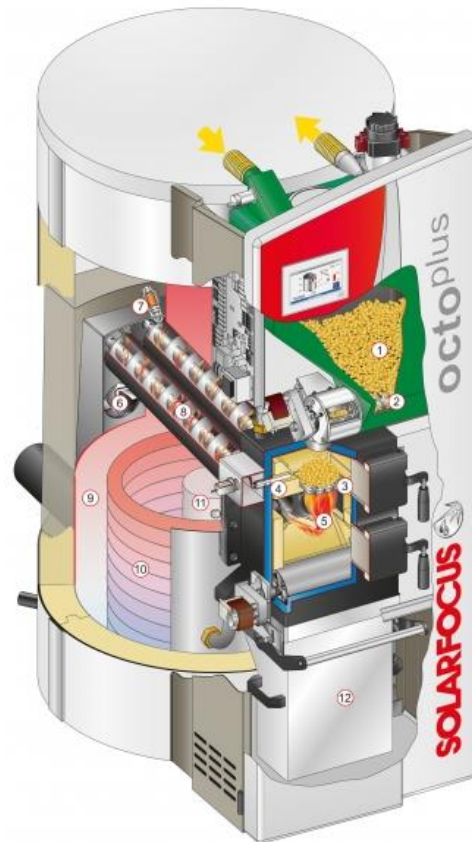

1. Intermediate container for pellets with suction turbine
2. Pellet auger with single axis rotary valve
3. Stainless steel grate
4. Automatic ignition
5. Downfiring combustion technology / pellets gasification
6. Induced draft fan
7. Lambda sensor
8. Heat exchanger cleaning system
9. 550/800 liters of storage volume
10. Solar register
11. Layer charging lance
12. Autom. ash extraction

[www.solarfocus.com](http://www.solarfocus.com)

# Biomass Boiler – Solar Thermal - current R&D Superordinate control for hybrid heating system

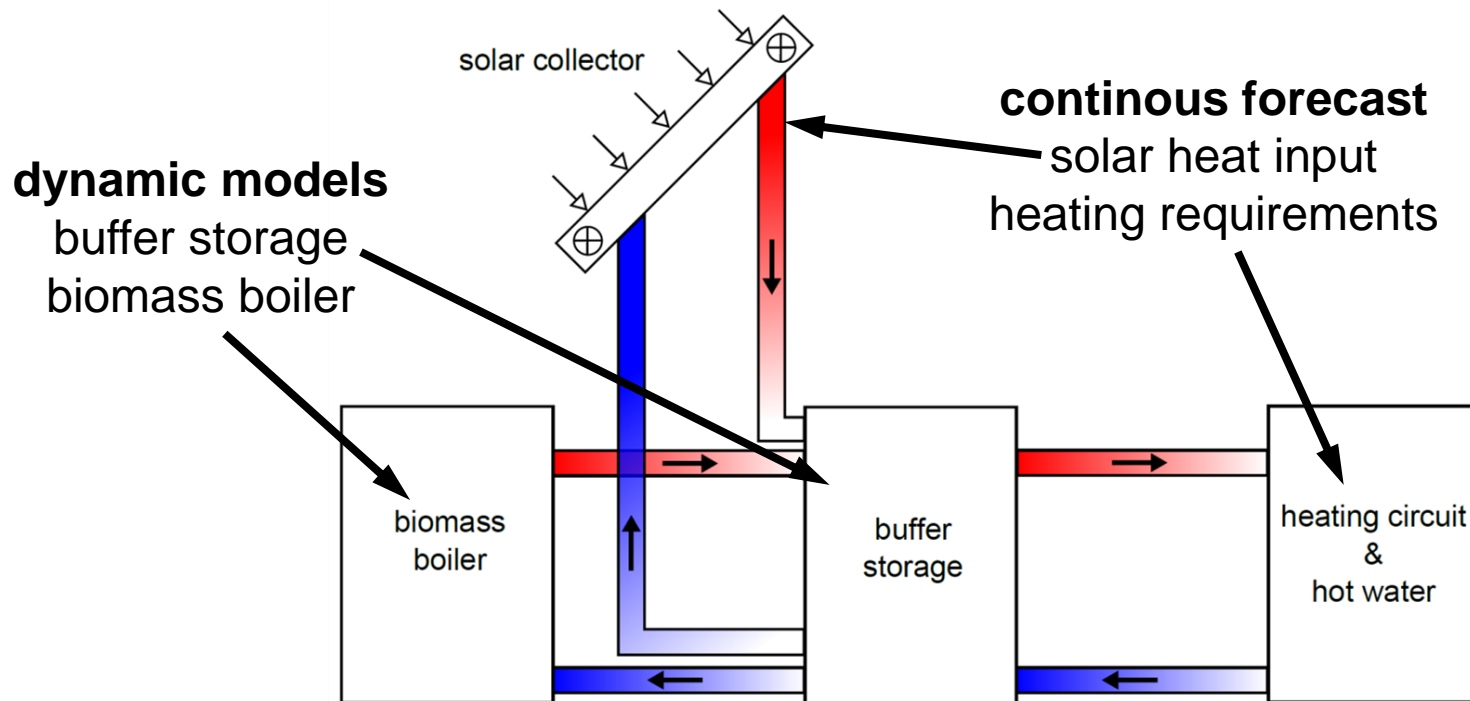

**Continuous prediction of the optimal boiler operation**  
 → minimal primary energy consumption (biomass & electricity)

# Pellet Boiler – air/water heat pump Guntamatic – Hybrid Flex

- Air/water heat pump
  - Low heat consumption
  - Warm water production in summer
- Pellet boiler
  - High heat consumption in winter
- Suitable especially for houses with floor heating systems

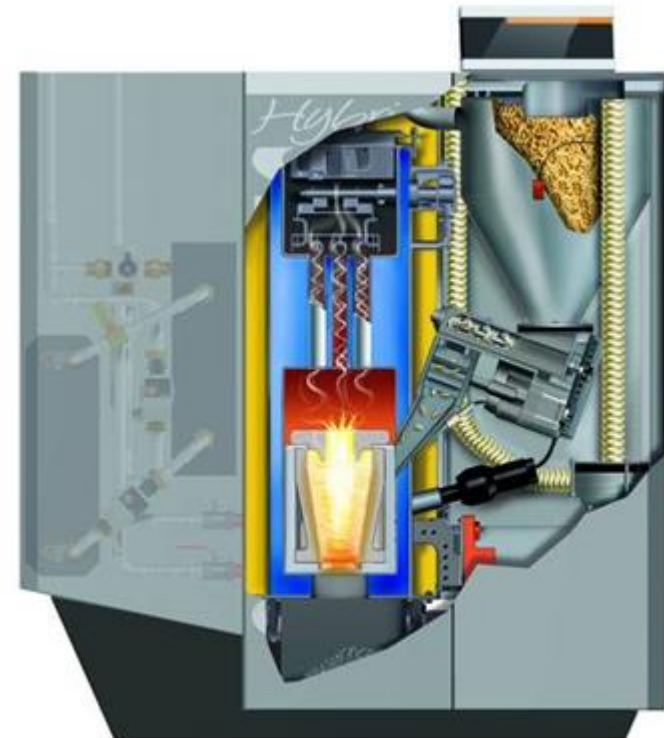

# Tiled Stove (Log Wood) + Heat Pump Ortner / BIOENERGY 2020+ - close to market



- Tiled stove manufactured with prefabricated elements
- Integration of a heat pump into hypocausts
- Expansion to central heating system

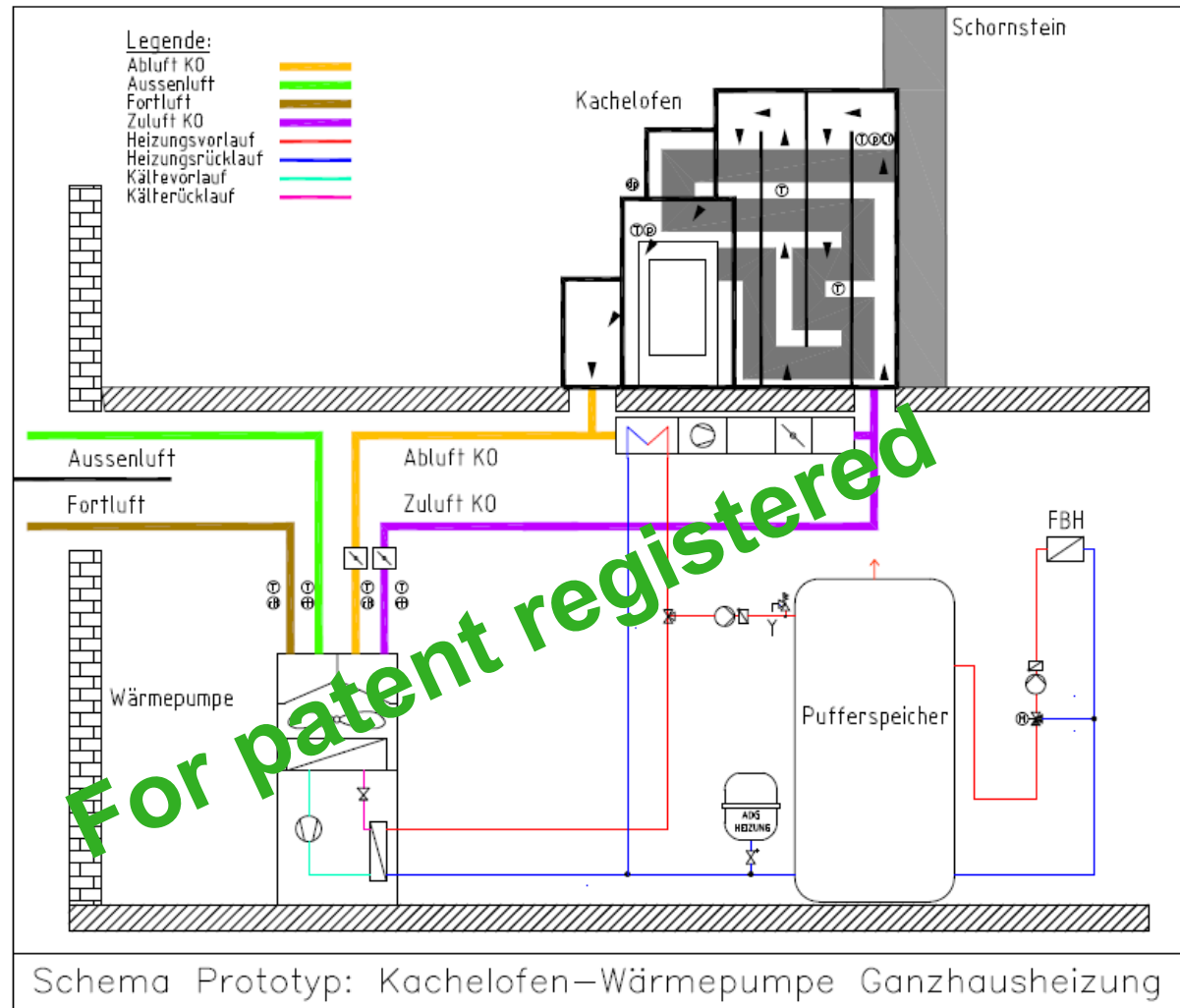

Brussels, June 15th 2016

# Biomass Boiler – Photovoltaic ÖkoFEN Smart PV

- Excess electrical Power is utilized in heat storage tank
- Weather forecast

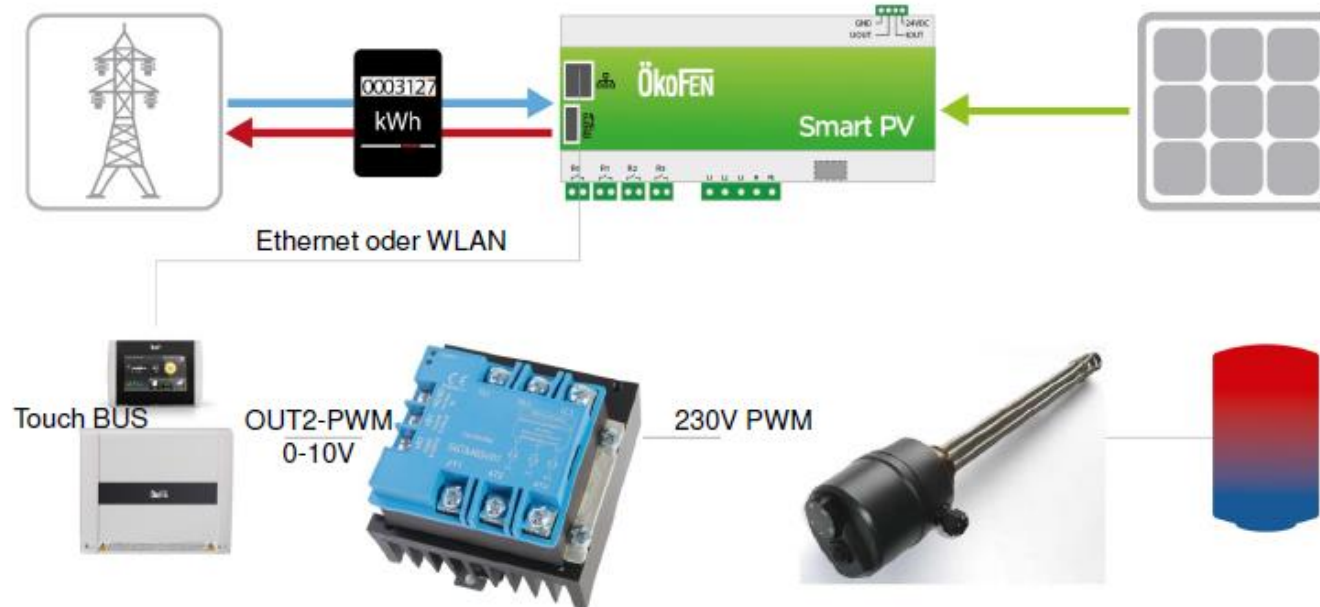

Source: Ökofen

# Active Condensation Systems Principle

- High losses depending on water content and flue gas temperature

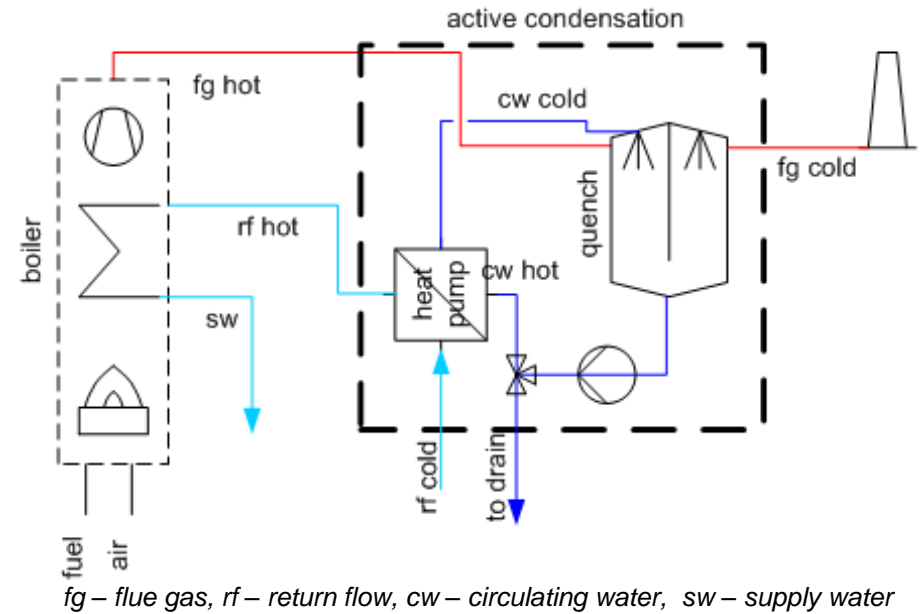
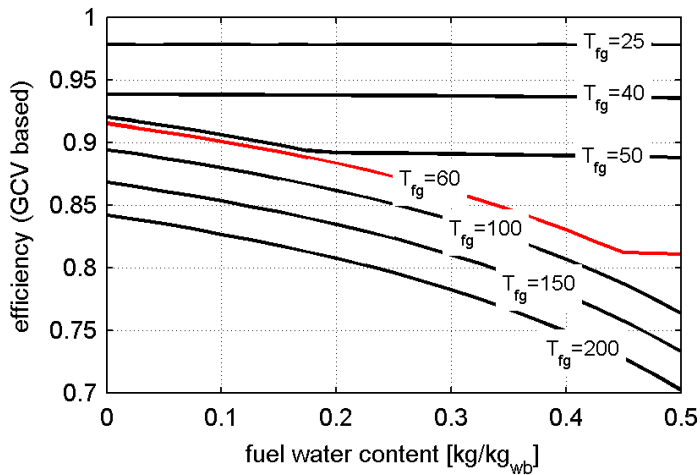

- Condensing system + heating pump

# Active Condensation Systems ongoing research - Open Sorption

- Condensation by sorption liquid
- Reduction of flue gas water content
- Reduction of PM expected
- First experiments planned for summer

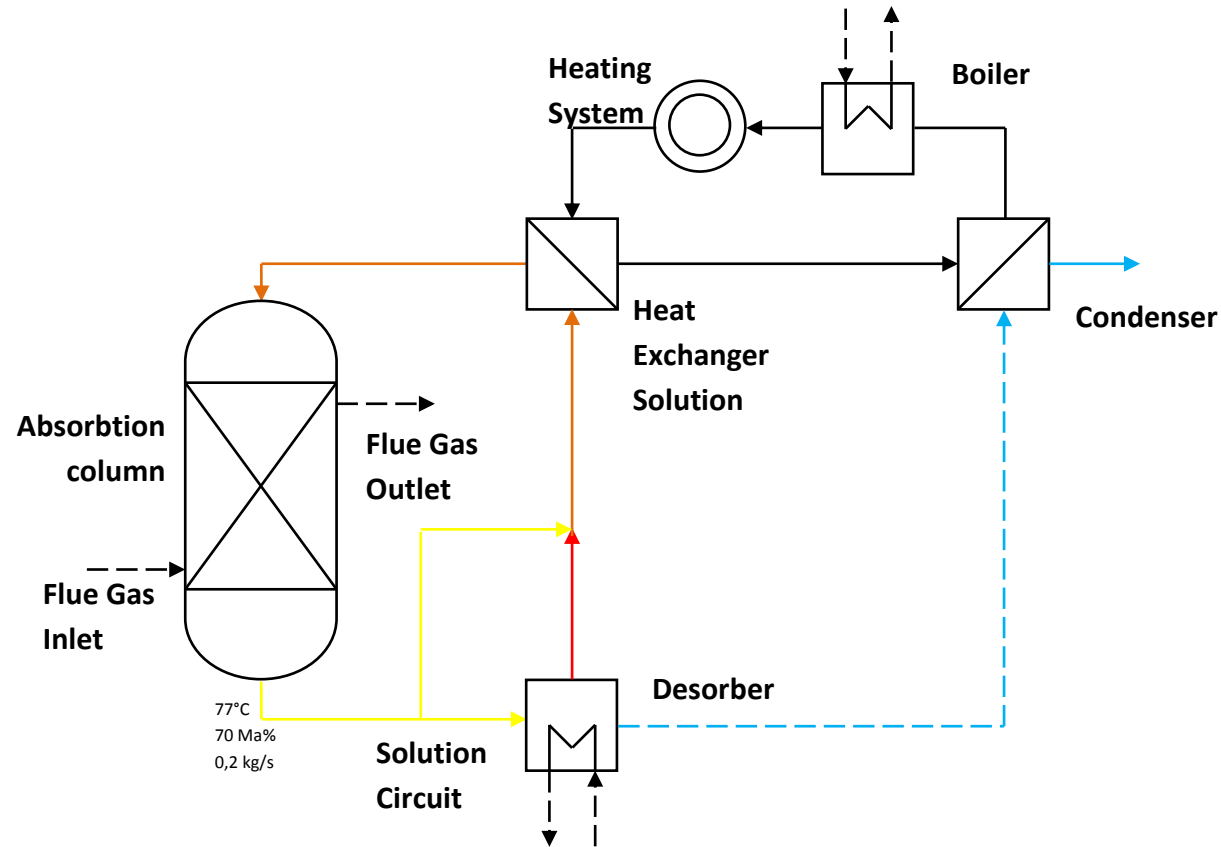

# Active Condensation Systems Biomass Boiler + Compression Heat Pump

## Tamsweg – CHP Plant



Hydraulics Plant

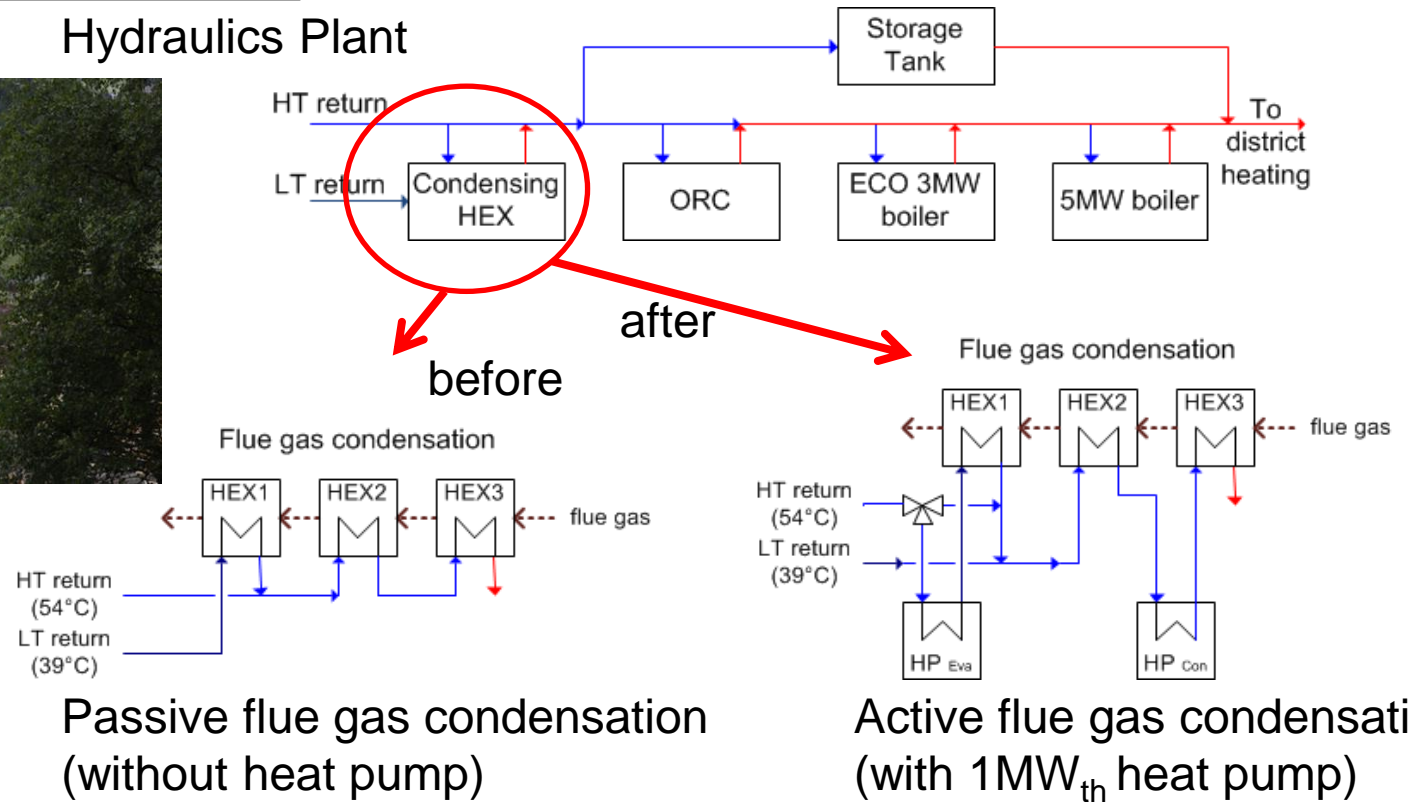

Passive flue gas condensation  
(without heat pump)

Active flue gas condensation  
(with 1MW<sub>th</sub> heat pump)

# Solarthermie + heating grids example: Gleisdorf

[http://www.aee.at/aee/index.php?option=com\\_content&view=article&id=681:solare-nahwaermesysteme-in-europa-large-scale-heating-systems-for-housing-developments&catid=63](http://www.aee.at/aee/index.php?option=com_content&view=article&id=681:solare-nahwaermesysteme-in-europa-large-scale-heating-systems-for-housing-developments&catid=63)

- Several office buildings
- Low energy consumption
- Heat supply:
  - ~ 50% solar heat
  - ~ 50% pellets
- 14 m<sup>3</sup> heat storage tank
- Heating system: 40°C
- Hot water loading: 65°C – 2 hours in night

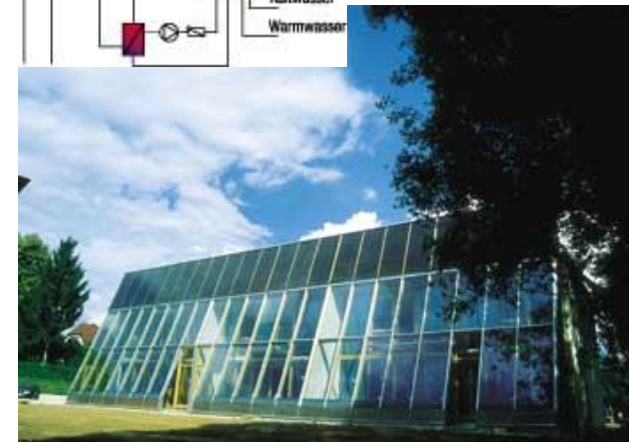
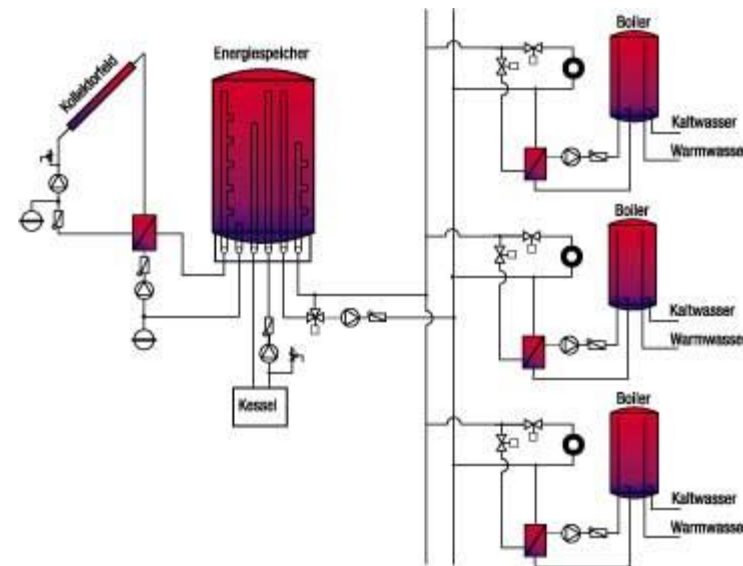

# Bidirectional Heating Grids Ongoing Research

## ■ Conventional Heating Grid

- Central heat production
- Consumers along the network

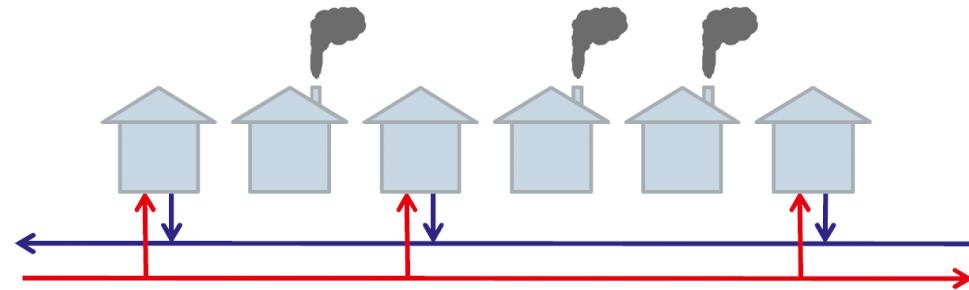

## ■ Bidirectional Heating Grids

- Additional decentral heat production by prosumers (**P**roducer and **C**onsumer)
- Possible heat sources: biomass boilers, solar thermal, industrial excess heat,...

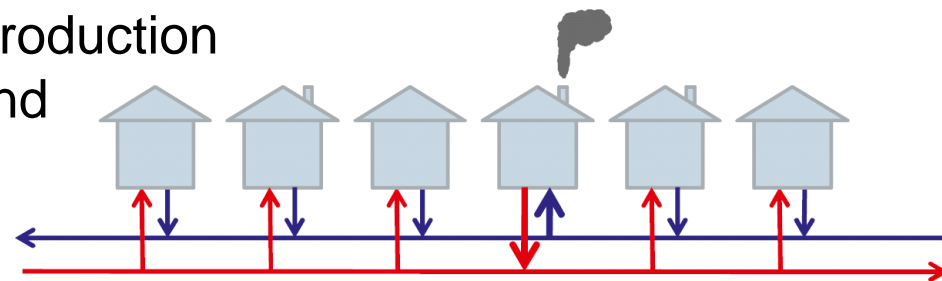

# Utilization of Animal By-products (ABP) + Geothermal Power

- ABP → Biogas
- Biogas → CHP
  - Partial self-supply
- Additional heat by geothermal power.



<http://www.grossfurtner.at/produktion/umwelt.html>

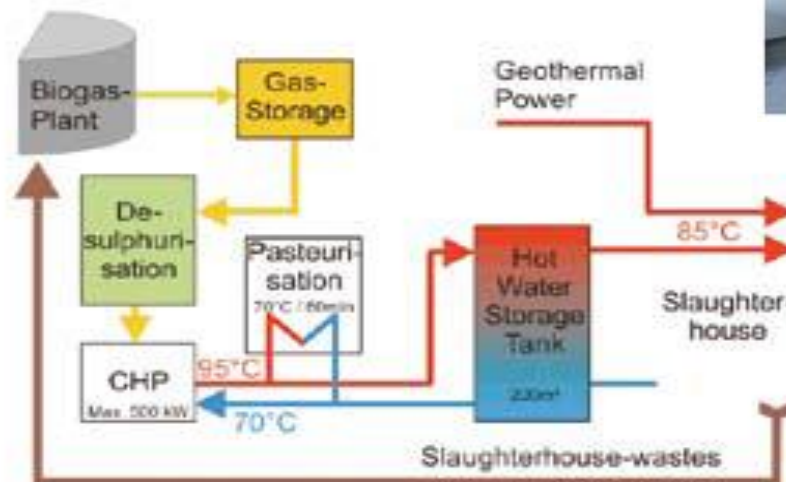

# Research – Winddiesel Windpower → Diesel

- windpower is converted by electrolysis to hydrogen
- hydrogen is added to synthesis gas from a biomass gasifier.
- work focus: development of a slurry reactor, suitable to be operated between 30% and 100% load.

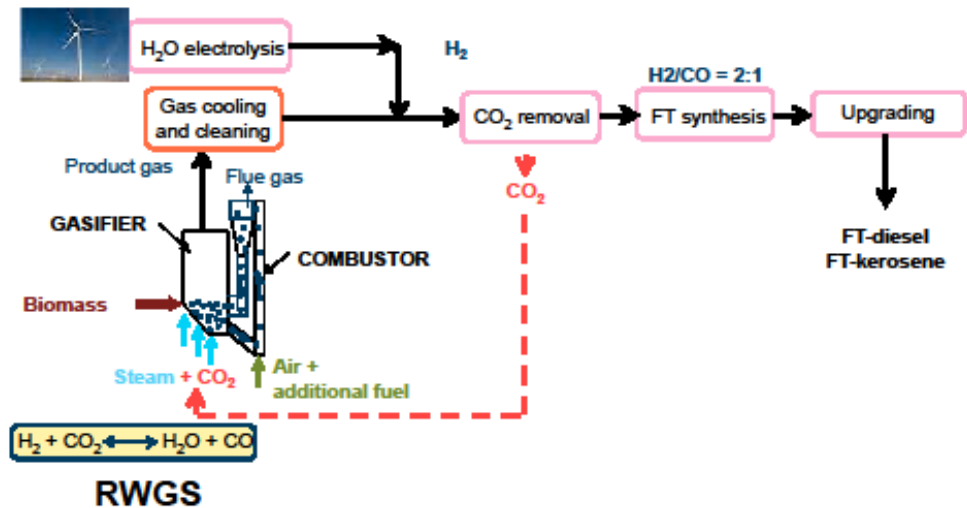

[http://www.nachhaltigwirtschaften.at/iea\\_pdf/events/20141121\\_fachgesprach\\_bioenergie\\_forschung\\_2014\\_vortrag\\_15\\_zweiler.pdf](http://www.nachhaltigwirtschaften.at/iea_pdf/events/20141121_fachgesprach_bioenergie_forschung_2014_vortrag_15_zweiler.pdf)

# BioConSolar

[http://eeg.tuwien.ac.at/eeg.tuwien.ac.at\\_pages/events/iewt/iewt2015/uploads/fullpaper/P\\_304\\_Schidler\\_Susanne\\_9-Feb-2015\\_16:56.pdf](http://eeg.tuwien.ac.at/eeg.tuwien.ac.at_pages/events/iewt/iewt2015/uploads/fullpaper/P_304_Schidler_Susanne_9-Feb-2015_16:56.pdf)

## ORC process

### Energy Sources:

- Biomass Boiler
- Concentrated Solar Power

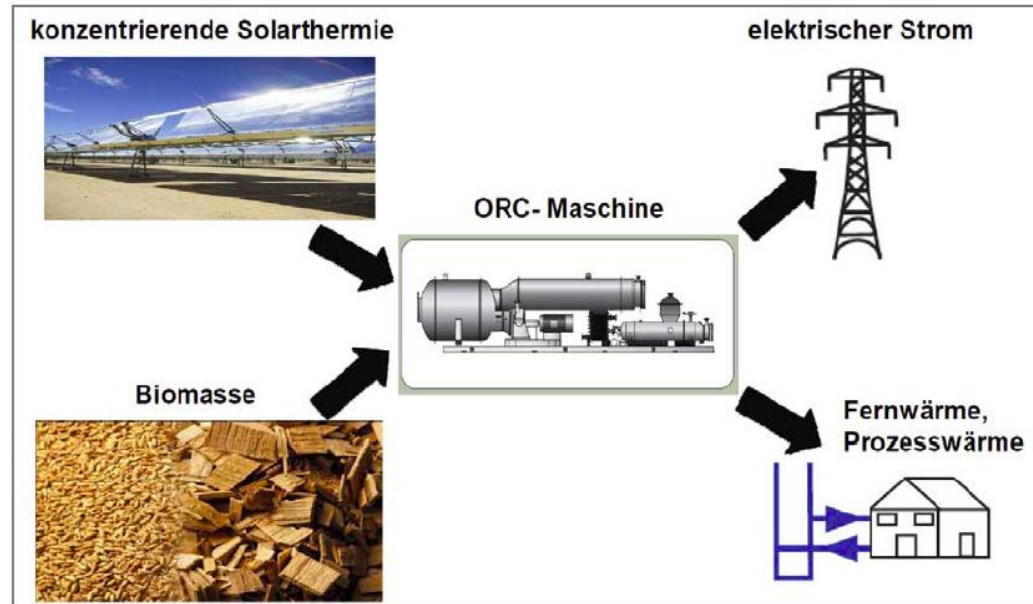

- Additional heat utilized in district heating grid

# Biomass + Heat Pump Herz – BioWP

- Heat pump
  - Summer operation
  - Backup system
- Applications:
  - New buildings with high heat demand
  - Different temperature levels within building
  - heating & cooling
  - District heating
  - Micro-grids

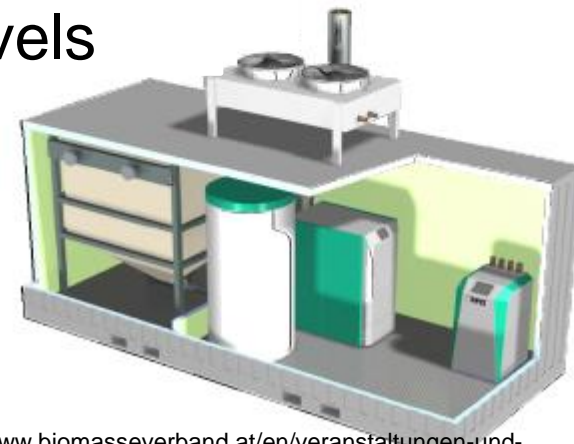

[http://www.biomasseverband.at/en/veranstaltungen-und-bildung/tagungen-und-vortraege/19-oesterreichischer-biomassetag/?eID=dam\\_frontend\\_push&docID=3960](http://www.biomasseverband.at/en/veranstaltungen-und-bildung/tagungen-und-vortraege/19-oesterreichischer-biomassetag/?eID=dam_frontend_push&docID=3960)

# Summary

	Domestic/household	Big scale
On market / implemented	<ul style="list-style-type: none"> <li>• Biomass / solar thermal</li> <li>• Biomass / heat pump</li> <li>• Biomass / PV</li> </ul>	<ul style="list-style-type: none"> <li>• Biomass / heat pump</li> <li>• Biomass / Solar thermal</li> <li>• Special solutions (e.g. slaughterhouse/Biogas)</li> </ul>
Ongoing developments / Outlook	<ul style="list-style-type: none"> <li>• Integrated control systems</li> <li>• Model predictive control</li> <li>• Increase market penetration</li> </ul>	<ul style="list-style-type: none"> <li>• Utilization of excess electrical energy (Power to Gas, Power to Liquid)</li> <li>• Integration of Prosumers into heating grids</li> <li>• Increase of market penetration</li> </ul>

# Contact

**Thank you for your Audience!**

IEA FORSCHUNGS  
KOOPERATION

bm  

## Contact and further information:

Ernst Höftberger

BIOENERGY 2020+ GmbH

Gewerbepark Haag 3

A-3250 Wieselburg Land

Tel +43 7416 522 38 - 22

E-mail: [ernst.hoefberger@bioenergy2020.eu](mailto:ernst.hoefberger@bioenergy2020.eu)

[www.bioenergy2020.eu](http://www.bioenergy2020.eu)